

Technical Data

Operating Voltage	17—28V dc
Sounder Output	
High Volume Setting*	nominally 66.8-77.6dB(A) at 10ft
Low Volume Setting	nominally 52.5-66.7dB(A) at 10ft

* For local notification, not for evacuation use.

Current Consumption at 24V dc (with Protocol Polling)	Sounder Beacon Bases
Normal Standby	<900µA
Switch-On Surge	1.2mA for 1 sec
Sounder/Beacon Operating	8.75mA

Commissioning

It is important that the base be fully tested after installation. Commission a base to a general sounder group in the fire alarm control panel using the panels recommended instructions. Create an alarm and ensure the base performs as programmed. Please use the panels own instructions when commission.

Troubleshooting

Problem	Possible Cause
No response or missing	Incorrect address setting Incorrect loop wiring (polarity reversed) Too many bases between isolators Sounder failed (if sounder base product)
Analog value 1	Beacon failed (if beacon base product)
Analog value 2	Sounder and beacon failed (if sounder beacon base product)
Analog value 3	Incorrect group address or address setting
Analog value 4	Control panel has incorrect cause and effect programming
Failure to operate	Incorrect group address setting

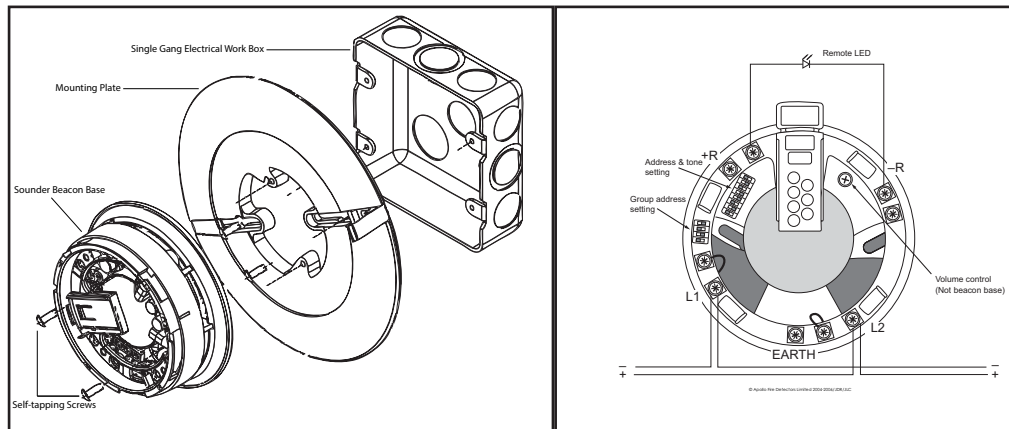

Fig. 2- Adaptor plate

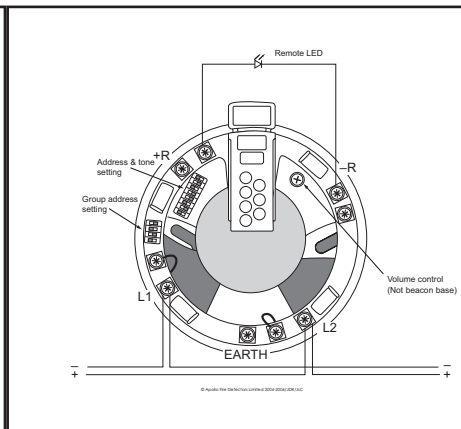

Fig. 3- Sounder Beacon Base wiring

©Apollo Fire Detectors Ltd 2017

Apollo Fire Detectors Ltd, 36 Brookside Road, Havant, Hants, PO9 1JR, UK
Tel +44 (0)23 9249 2412 Fax +44 (0)23 9249 2754

Email: techsales@apollo-fire.com Website: www.apollo-fire.co.uk

In the USA: Apollo America Inc., 25 Corporate Drive, Auburn Hills, Michigan, 48326, USA

Tel: (248) 332-3900 Fax: (248) 692-0888

Email: info.us@apollo-fire.com Website: www.apollo-fire.com



XP95A Sounder Beacon Base Installation Guide

General

This guide describes the installation of the following base variants

Part Number	Product Description
45681-525	XP95A Sounder Beacon Base (Yellow LED's)
45681-526	XP95A Sounder Beacon Base (Red LED's)
45681-292	White Cap only (Lockable)
45681-293	Red Cap only (Lockable)

Connect the devices only to control panels using the XP95 protocol.

All XP95A Sounder Beacon Base variants combine a sounder with a beacon and a detector base in one unit. The beacon is activated whenever the sounder is active and cannot be controlled separately.

Note: All XP95A Sounder Beacon Bases are not suitable for outdoor use. No is it intended for evacuation notification use.

Installation of Mounting Plate

On a single gang electrical work box, align the recessed mounting grooves at each side of the included mounting plate over the screw holes of the work box and tighten screws until the plate is secure.

On dual gang and octagon electrical work boxes, make sure that two screws at opposing corners of the box are tightened halfway down. Align the screw slot on the mounting plate within the longer mounting groove over one of the screws. Slide the mounting plate slightly to allow the remaining screw to come through the appropriate slot. For a dual gang work box, this will be the outer screw slot, allowing the screw to slide securely into the outer rim mounting notch. Tighten the screws until the mounting plate is secure. Drill included self-tapping screws halfway down into the .125in diameter holes on the inner tabs of the mounting plate. Make sure both hinged screw covers snap closed before placing the Sounder Beacon Base on the mounting plate. Hold the Sounder Beacon Base over the raised screws at a slight angle, allowing the screws to catch the mounting notches on the underside of the base. Tighten the base mounting screws as necessary. Once the base is secure, make sure that all wiring is pulled through. Terminate all wiring as shown in Fig. 3.

Wiring Details

Note: These products are polarity sensitive (supply reverse protected) and will not function if wired incorrectly.

Connect the positive and negative loop cables to the L2 and L1 terminals respectively, observing polarity. The wiring terminals accept solid or stranded cables up to 24AWG -14AWG. Functional earth or screen cables may be terminated to the EARTH connection.

When using as a stand-alone unit, a cap is available (red cap Part No. 45681-293 or white cap Part No. 45681-292) and is secured with a 1.5mm, Allen screw. An Allen Wrench (Part No. 29600-095) is available from Apollo.

Address Setting

The address of the XP95A Sounder Beacon Bases are set using seven segments of the eight-segment DIL switch. The eighth segment is used to adjust the volume output. Segments 1-7 of the switch are set to "0" (ON) or "1" (OFF), using a small screwdriver or similar tool. A complete list of address settings is shown below. If a detector is to be fitted, set the address as described on page 3.

DIL switch setting		DIL switch setting		DIL switch setting		DIL switch setting		DIL switch setting	
addr	1234567	addr	1234567	addr	1234567	addr	1234567	addr	1234567
1	1000000	11	1101000	21	1010100	31	1111100	41	1001010
2	0100000	12	0011000	22	0110100	32	0000010	42	0101010
3	1100000	13	1011000	23	1110100	33	1000010	43	1101010
4	0010000	14	0111000	24	0001100	34	0000100	44	0011010
5	1010000	15	1111000	25	1001100	35	1100010	45	1011010
6	0110000	16	0000100	26	0101100	36	0010010	46	0111010
7	1110000	17	1000100	27	1101100	37	1101010	47	1111010
8	0001000	18	0100100	28	0011100	38	0110010	48	0000110
9	1001000	19	1100100	29	1011100	39	1110010	49	1000110
10	0101000	20	0010100	30	0111100	40	0001010	50	0100110
51	1100110	61	1011110	71	1110001	81	1000101	91	1101101
52	0010110	62	0111110	72	0001001	82	0100101	92	0011101
53	1010110	63	1111110	73	1001001	83	1001001	93	1011101
54	0110110	64	0000001	74	0101001	84	0010101	94	0111101
55	1110110	65	1000001	75	1101001	85	1010101	95	1111101
56	0001110	66	0100001	76	0011001	86	0110101	96	0000011
57	1001110	67	1100001	77	1101001	87	1110101	97	1000011
58	0101110	68	0010001	78	0111001	88	0001101	98	0100011
59	1101110	69	1010001	79	1111001	89	1001101	99	1100011
60	0011110	70	0110001	80	0000101	90	0101101	100	0010011
101	1010011	106	0101011	111	1111011	116	0010111	121	1001111
102	0110011	107	1101011	112	0000111	117	1010111	122	0101111
103	1110011	108	0011011	113	1000111	118	0110111	123	1101111
104	0001011	109	1011011	114	0100111	119	1110111	124	0011111
105	1001011	110	0111011	115	1100111	120	0001111	125	1011111
								126	0111111

Group Address Setting

In group mode the XP95A Sounder Beacon Base respond to an additional address referred to as the group address, which is used to activate groups of base variants simultaneously. Individual units continue to respond to their own addresses and report their status in the normal way. A group address is set on a four-segment DIL switch which is factory set to 0000. A group address may be any spare address within—and only within—the range 112 to 126 inclusive. The required group address is set in accordance with the following table. For an illustrated example, please see Fig. 1.

DIL switch setting		DIL switch setting		DIL switch setting	
addr	1234	addr	1234	addr	1234
112	1111	117	0101	122	1010
113	0111	118	1001	123	0010
114	1011	119	0001	124	1100
115	0011	120	1110	125	0100
116	1101	121	0110	126	1000

Note: group mode is disabled if the group address DIL switch is set to 0000, irrespective of the protocol message.

The Sounder Beacon Bases are tested via the control panel. Output bit 0 is set to 1 on two polling cycles to switch the sounder on which should be tested for at least 5 seconds.

Tone

Alert Tone 2900Hz continuous
 Evacuate Tone (2900Hz for 0.5sec, silence for 0.5sec) ANSI Temporal pattern

Frequency

The tones are not set by DIL switches. They are set by the panel using the Output command bits 1 and 0 of the protocol. Output Command Bit 0 controls the Evacuate Tone and Output Command Bit 1 controls the Alert tone. The Evacuate Tone overrides the Alert Tone.

Output Command Bits	2	1	0	
	X	0	1	Evacuate Tone
	X	1	0	Alert Tone
	X	1	1	Evacuate Tone

VOLUME

The volume range is set using DIL switch 8 as shown in Fig. 1. The final volume, within its range, is set using the volume control potentiometer.

XPERT Card Addressing

Select the desired address and remove the pips indicated in black. Remove pips with a small screwdriver.

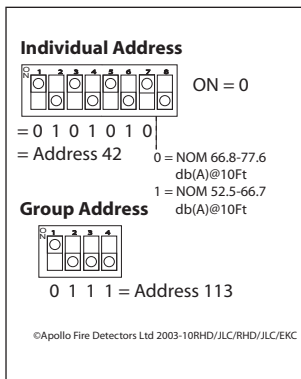

Fig. 1- Address example

