

XP95

Optical Smoke Detector



Product overview

Product	Optical Smoke Detector
Part No.	55000-600
Product	Optical Smoke Detector
Part No.	55000-620
Product	Optical Smoke detector - black
Part No.	55000-660
Digital Communication	XP95, Discovery and CoreProtocol® compatible

Compliance*



Note: Compliance*

Part No. 55000-600; CPR, LPCB only

Part No. 55000-620; CPR, LPCB, VdS, BOSEC, CCMG, FG, SBSC

Part No. 55000-660; CPR, LPCB only

Product information

The XP95 Optical Smoke Detector works on the light scatter principle and is ideal for applications where slow burning or smouldering fires are likely.

- Responds well to slow burning, smouldering fires
- Well suited to escape routes
- Unaffected by wind or atmospheric pressure

Technical data

All data is supplied subject to change without notice. Specifications are typical at 24 V, 25°C and 50% RH unless otherwise stated.

Detection principle	Photo-electric detection of light scattered in a forward direction by smoke particles
Chamber configuration	Horizontal optical bench housing an infrared emitter and sensor arranged radially to detect scattered light
Sensor	Silicon PIN photo-diode
Emitter	GaAs infra-red light emitting diode
Sampling frequency	Once per second
Sensitivity	Nominal response threshold value of 0.12 dB/m when measured in accordance with EN 54-7
Supply Wiring	Two wire supply, polarity insensitive
Terminal functions	L1 & L2 Loop in & out positive +R Remote indicator positive connection (internal 2.2 kΩ resistance to supply +ve) -R Remote indicator negative connection (internal 2.2 kΩ resistance to supply -ve)
Supply voltage	17 V to 28 V dc
Digital communication	XP95, Discovery and CoreProtocol compatible
Quiescent current	340 μA
Power-up surge current	1 mA for 1 second
Alarm indicator	Clear light emitting diode (LED) emitting red light
Alarm LED current	4 mA
Remote LED current	5 mA maximum
Storage temperature	-30°C to +80°C
Operating temperature	-20°C to +60°C
Humidity	0% to 95% RH (no condensation or icing)
Effect of atmospheric pressure	Unaffected
Effect of wind speed	Unaffected by wind
Vibration, impact and shock	EN 54-7
Standards and approvals*	EN 54, CPR, LPCB, VdS, BOSEC, SBSC, CCMG, FG
Dimensions	100 mm diameter x 42 mm height
Weight	105 g
Materials	Housing: White flame-retardant polycarbonate Terminals: Nickel plated stainless steel

All information in this document is given in good faith but Apollo Fire Detectors Ltd cannot be held responsible for any omissions or errors. The company reserves the right to change the specifications of products at any time and without prior notice.

36 Brookside Road, Havant
Hampshire, PO9 1JR, UK.

Tel: +44 (0)23 9249 2412
Fax: +44 (0)23 9249 2754

Email: sales@apollo-fire.com
Web: www.apollo-fire.co.uk



Operation

The XP95 Optical Smoke Detector uses the same outer case as the ionization smoke detector and is distinguished by the indicator LED which is clear in standby and red in alarm. Within the case is a printed circuit board which on one side has the light proof labyrinth chamber with integral gauze surrounding the optical measuring system and on the other the address capture, signal processing and communications electronics.

An infrared light emitting diode within its collimator is arranged at an obtuse angle to the photo-diode. The photo-diode has an integral daylight blocking filter.

The infrared LED emits a burst of collimated light every second. In clear air the photo-diode receives no light directly from the infrared LED because of the angular arrangement and the dual mask. When smoke enters the chamber it scatters photons from the emitter infrared LED onto the photo-diode in an amount related to the smoke characteristics and density. The photo-diode signal is processed by the optical ASIC and passed to the A/D converter on the communications ASIC ready for transmission when the device is interrogated.

Electrical description

The XP95 Optical Smoke Detector is designed to be connected to a two wire loop circuit carrying both data and a 17 V to 28 V dc supply. The detector is connected to the incoming and outgoing supply via terminals L1 and L2 in the mounting base. A remote LED indicator requiring not more than 4 mA at 5 V may be connected between the +R and -R terminals. An earth connection terminal is also provided. The detector is calibrated to give an analogue value of 25 ± 7 counts in clean air. This value increases with smoke density. A count of 55 corresponds to the EN 54 alarm sensitivity level.

Environmental characteristics

The XP95 Optical Smoke Detector is unaffected by wind or atmospheric pressure and operates over the temperature range -20°C to $+60^{\circ}\text{C}$.

Remote LED connection

A drive point is provided on the XP95 Optical Smoke Detector for a remote LED indicator. The indicator must be a standard high-efficiency RED LED and does not require a series limiting resistor since current is limited within the detector to approximately 1 mA.

XP95 Optical Smoke Detector sectional view

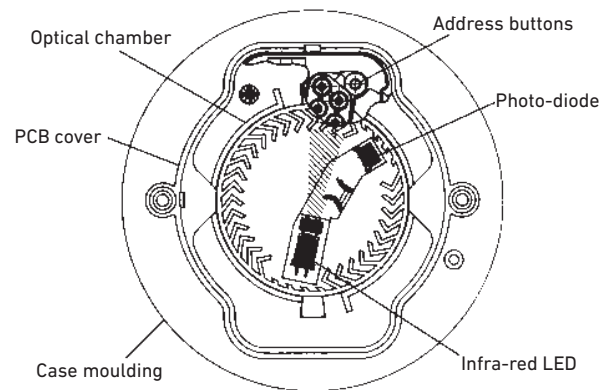

XP95 Optical Smoke Detector dimensions

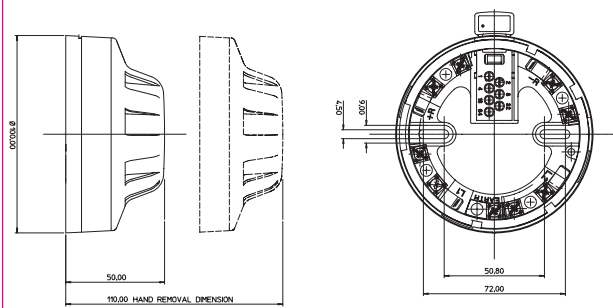

EMC Directive 2014/30/EU

The XP95 Optical Smoke Detector complies with the essential requirements of the EMC Directive 2014/30/EU, provided that it is used as described in this data sheet.

A copy of the Declaration of Conformity is available from Apollo upon request.

Construction Products Regulation 305/2011/EU

The XP95 Optical Smoke Detector complies with the essential requirements of the Construction Products Regulation 305/2011/EU.

A copy of the Declaration of Performance is available from Apollo upon request.

