

Discovery Marine Optical Smoke Detector



Technical Data

All data is supplied subject to change without notice. Specifications are typical at 24V, 23°C and 50% RH unless otherwise stated.

Detection principle	Photo-electric detection of light scattered in a forward direction by smoke particles
Chamber configuration	Horizontal optical bench housing an infrared emitter and sensor arranged radially to detect forward scattered light
Sensor	Silicon PIN photo-diode
Emitter	GaAlAs infra-red light emitting diode
Sampling frequency	Once per second
Supply Wiring	Two wire supply, polarity insensitive
Terminal functions	L1 & L2 Supply in & out connections +R Remote indicator positive connection (internal 2.2 kΩ resistance to positive) -R Remote indicator negative connection (internal 2.2 kΩ resistance to negative)
Digital communication	XP95, Discovery and CoreProtocol compatible 5-9 V peak to peak
Operating voltage	17 V - 28 V dc
Quiescent current	300 μA
Power-up surge current	1 mA
Maximum power-up time	10 seconds
Alarm indicator	Two clear 360° viewable light emitting diode (LED) illuminating red in alarm. Optional remote LED
Alarm current, LED illuminated	3.5 mA
Remote output characteristics	Connects to positive line through 4.5 kΩ (5 mA maximum)
Clean-air analogue value	23 +4/-0
Alarm level analogue value	55
Operating temperature	-40°C to +70°C
Storage temperature	-40°C to +80°C
Humidity	0% to 95% RH (no condensation or icing)
Effect of atmospheric pressure	None
Effect of wind	None
Vibration, impact & shock	EN54 - 7
IP Rating	designed to IP44
Standards & approvals	EN 54-7, CPR, LPCB, MED, LR, DNV-GL, BV, ABS, CCS, KRS and VNIPO
Dimensions	100 mm diameter x 42 mm height (50 mm height with XPERT 7 base)
Weight	105 g (160 g with XPERT 7 mounting base)
Materials	Housing White flame-retardant polycarbonate Terminals Nickel plated stainless steel

Product Overview

Product Type	Marine Optical Smoke Detector
Part No.	58000-600MAR
Digital Communication	XP95, Discovery and CoreProtocol® compatible

Approvals



Product Information

The Discovery Marine Optical Smoke Detector works on the light scatter principle and is ideal for applications where slow burning or smouldering fires are likely.

- Responds well to slow burning, smouldering fires
- Well suited for accommodation decks, passages and escape routes
- Unaffected by wind or atmospheric pressure
- Rejection of transient signals
- Remote test feature
- Five EN54 approved response modes

36 Brookside Road, Havant Hampshire, PO9 1JR, UK. | Tel: +44 (0)23 9249 2412 | Email: sales@apollo-fire.com
Fax: +44 (0)23 9249 2754 | Web: www.apollo-fire.co.uk



A HALMA COMPANY

© Apollo Fire Detectors Limited 2017



Operation

The Discovery Marine Optical Smoke Detector has a white moulded polycarbonate case with wind-resistant smoke inlets. The indicator LEDs are colourless when the detector is in quiescent state and red in alarm. Within the case is a printed circuit board which on one side has the light proof labyrinth chamber with integral gauze surrounding the optical measuring system and on the other the address capture, signal processing and communications electronics.

An infrared light emitting diode within its collimator is arranged at an obtuse angle to the photo-diode. The photo-diode has an integral daylight blocking filter.

The IR LED emits a burst of collimated light every second. In clear air the photo-diode receives no light directly from the IR LED because of the angular arrangement and the chamber baffles. When smoke enters the chamber it scatters light from the emitter IR LED onto the photo-diode in an amount related to the smoke characteristics and density. The photo-diode signal is processed to provide an analogue value for transmission when the detector is interrogated.

Features

Response modes

Discovery Marine Optical Smoke Detectors can be operated in any one of five EN54 approved response modes, which can be selected through the fire control panel. Each mode corresponds to a unique response behaviour, which is related to sensitivity to fire. Mode 1 gives a higher sensitivity to fire than Mode 5.

Discovery Marine Optical Smoke Detector Response Times			
Mode	Alarm threshold (%/m)	dB/m	Minimum time to alarm (Seconds)
1	1.4	0.08	5
2	1.4	0.08	30
3	2.1	0.12	5
4	2.1	0.12	30
5	2.4	0.14	5

Flashing LEDs

Discovery Marine Optical Smoke Detectors have two integral LED indicators, which can be illuminated at any time by the fire control panel to indicate detectors in alarm. A flashing LED mode can also be programmed to activate each time a detector is polled.

Remote test feature

The remote test feature is enabled from the fire control panel. On receipt of the command signal from the fire control panel, the detector is forced electrically into alarm. An analogue value of 85 is returned to the fire control panel to indicate that the detector is working correctly.

Rejection of transient signals

Discovery detectors are designed to give low sensitivity to very rapid changes in the sensor output, since these are unlikely to be caused by real fire conditions, resulting in fewer false alarms.

Drift compensation

Discovery Marine Optical Smoke Detectors include compensation for signal drift to compensate for changes in the sensor output caused, for example by dust in the chamber, and will therefore hold the sensitivity at a constant level even with severe chamber contamination. This increased stability is achieved without significantly affecting the detectors sensitivity to fire whilst still meeting the requirements of the EN54 standard.

Response characteristics of Discovery Optical Smoke Detectors	
Type of fire	Response
Overheating/thermal combustion	Very Good
Smouldering/glowing combustion	Moderate/Good
Flaming combustion	Good
Flaming with high heat output	Good
Flaming - clean burning	Poor

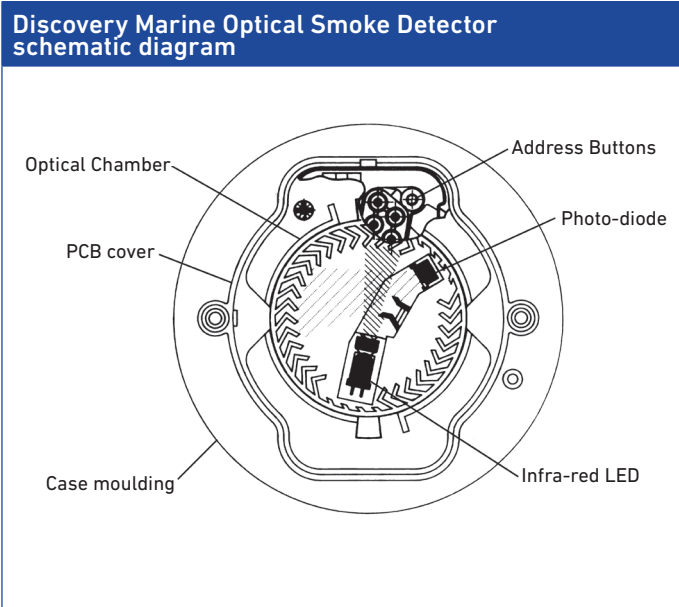

Electrical description

The Discovery Marine Optical Smoke Detector is designed to be connected to a two wire loop circuit carrying both data and a 17 V to 28 V dc supply. The detector is connected to the incoming and outgoing supply via terminals L1 and L2 in the mounting base. A remote LED indicator requiring not more than 4 mA at 5 V may be connected between the +R and -R terminals. An earth connection terminal is also provided. The detector is calibrated to give an analogue value of 23 +4/-0 counts in clean air. This value increases with smoke density. A count of 55 corresponds to the alarm level analogue value.

EMC Directive 2014/30/EU

The Discovery Marine Optical Smoke Detector complies with the essential requirements of the EMC Directive 2014/30/EU, provided that it is used as described in this data sheet.

A copy of the Declaration of Conformity is available from the Apollo website: www.apollo-fire.co.uk.

Construction Products Regulation 305/2011/EU

The Discovery Marine Optical Smoke Detector complies with the essential requirements of the Construction Products Regulation 305/2011/EU.

A copy of the Declaration of Performance is available from the Apollo website: www.apollo-fire.co.uk

Marine Equipment Directive 2014/90/EU

The Discovery Marine Optical Smoke Detector complies with the essential requirements of the Marine Equipment Directive 2014/90/EU.

Discovery Marine Optical Smoke Detector dimensions

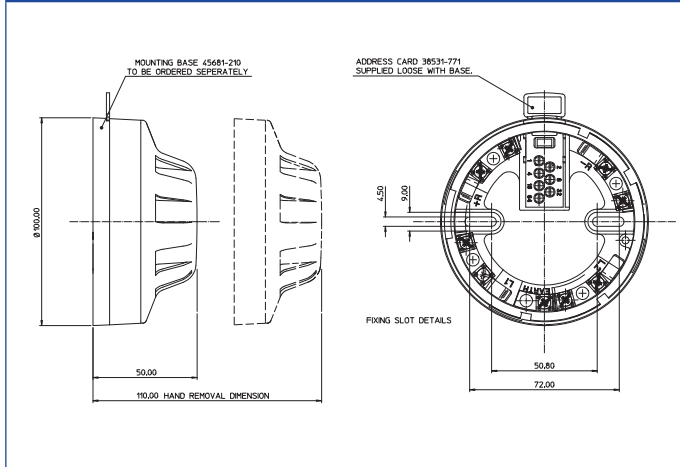

Note: Should be used with Deckhead Mounting Box - Part No. 45681-217 if ingress protection is required.

This page has intentionally been left blank

