

**Technical description.**

The LBC8 fuse module is designed for power distribution in CCTV systems requiring the voltage in the range 10V ÷ 30V DC. It is equipped with two power inputs: screw connection and DC jack 5.5/2.1 and eight AUX1 ÷ AUX8 power outputs independently protected with 1A melting fuses. PTC fuse activation is indicated by switching off the corresponding LED of the module: L1 for AUX1, L2 for AUX2 etc. Additionally, the module's input is protected by a varistor, protecting the power supply against surges in the power supply system.

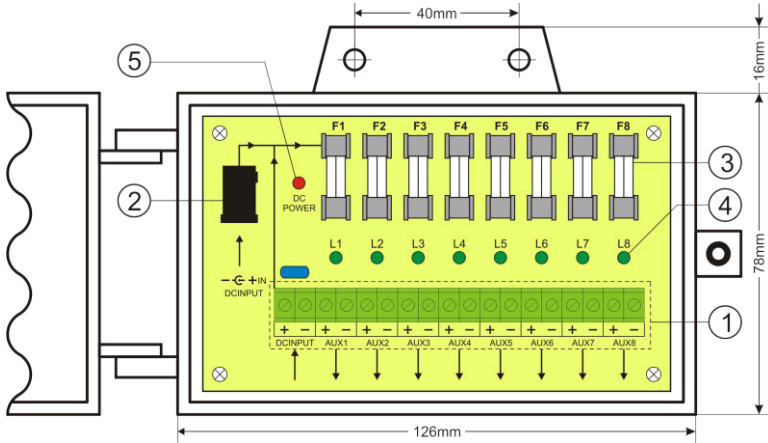

Fig.1. The scheme of the module.

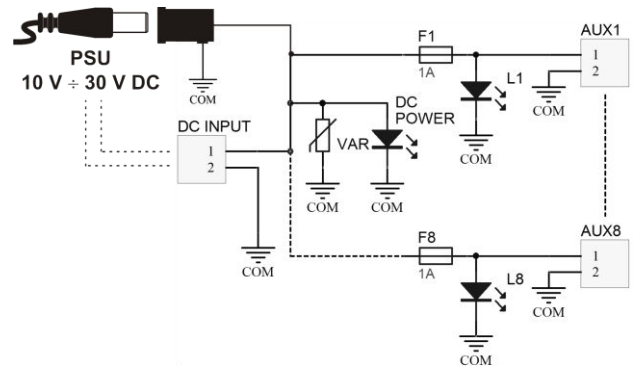

Fig.2. Block diagram.

**Table 1. The description of components and module connectors.**

Part no. [Fig. 2]	Description
①	<b>Terminals:</b> DC INPUT DC power input AUX1 ÷ AUX8 independently protected outputs, (common terminal „-“)
②	DC INPUT additional power input – DC jack 5,5/2,1
③	F1 ÷ F8 fuses in the AUX (+) circuit
④	L1 ÷ L8 green LEDs
⑤	DC POWER red LED

**Table 2. Technical parameters.**

<b>Supply voltage</b>	10V ÷ 30V DC
<b>Current consumption</b>	8 mA ÷ 70 mA @ U <sub>IN</sub> = 10V ÷ 30V DC
<b>Number of power inputs</b>	2: DC jack 5,5/2,1 or screw connection
<b>Number of power outputs</b>	8 (AUX terminals)
<b>Protection types:</b>	
- short-circuit protection SCP	- 8 x 1A
- overload protection OLP	- 8 x 1A
- surge protection	- varistor
<b>Optical indication</b>	Red LED – DC supply voltage indicator Green L1 ÷ L8 LEDs –AUX1 ÷ AUX8 outputs status
<b>Fuses F1 ÷ F8</b>	8 x F1A
<b>Operation conditions</b>	2nd environmental class, -10°C ÷ +40°C
<b>Dimensions</b>	W=150, H=94, D=42 (+/-2mm) W <sub>1</sub> =126, H <sub>1</sub> =78 (+/-2mm)
<b>Mounting</b>	Mounting screws x2 (Ø4mm holes)
<b>Connectors:</b>	
- supply outputs	- screw connection Ø0,51÷2,05 (AWG 24-12)
- supply inputs	- DC jack 5,5/2,1 - screw connection Ø0,51÷2,05 (AWG 24-12)
<b>Net/gross weight</b>	0,17kg / 0,24kg
<b>Declarations, warranty</b>	CE, 2 year from the production date

**WEEE LABEL**

Waste electrical and electronic equipment must not be disposed of with normal household waste. According to the European Union WEEE Directive, waste electrical and electronic equipment should be disposed of separately from normal household waste.

**Pulsar**

Siedlec 150, 32-744 Łapczyca, Poland  
Phone (+48) 14-610-19-40, Fax (+48) 14-610-19-50  
E-mail: [biuro@pulsar.pl](mailto:biuro@pulsar.pl), [sales@pulsar.pl](mailto:sales@pulsar.pl)  
http:// [www.pulsar.pl](http://www.pulsar.pl), [www.zasilacze.pl](http://www.zasilacze.pl)