

Soteria®

Heat Detector



Product overview

Product Type	Heat Detector
Part No.	SA5000-400 (non-isolated) SA5100-400 (isolated)
Digital Communication Protocol	XP95, Discovery & CoreProtocol® compatible

Product information

The Soteria Heat Detector features two heat sensors located laterally to ensure accurate heat detection in all orientations.

- Dual heat sensors
- Utilises digital CoreProtocol communications
- Compatible with XP95 and Discovery systems*
- Mechanically compatible with existing bases
- Available with or without integrated switchable isolator
- Tri-coloured LED status indicator
- Polycarbonate moulding for colour stability and strength
- Comprehensively tested to exceed EN 54-5 standard
- FasTest® for quicker testing of detectors
- XPERT 8 card addressing
- Locking mechanism (grub screw)

* Note: Not all features are available when Soteria devices are connected to an XP95 or Discovery fire control panel

Technical data

All data is supplied subject to change without notice. Specifications are typical at 24V, 25°C and 50% RH unless otherwise stated.

Detection principle	Heat sensitive resistance
Sensor configuration	Thermistor
Sampling frequency	Once per second
Terminal functions (note: L1 & L2 are polarity sensitive)	+L2 Loop in & out positive -L1 in Loop (isolated) negative -L1 out Loop (isolated) negative +R Remote indicator positive connection (internal connection to positive) -R Remote indicator negative connection (4.7mA maximum)

Supply voltage (V_{min} - V_{max})	17-35V DC
Digital communication protocol	XP95, Discovery & CoreProtocol compatible 5-13V peak to peak
Quiescent current	Isolated detector: 350µA Non-Isolated detector: 300µA
Power-up surge current	560µA
Maximum power-up time	10s
Alarm current, LED illuminated	3.5mA

Isolated detector data only

Maximum loop current ($I_{L,max}$; L1 in/out)	1A
Maximum series resistance ($Z_{L,max}$; L1 in/out)	80mΩ
Maximum switch current ($I_{S,max}$; L1 in/out)	3A
Maximum leakage current ($I_{L,max}$; during isolation)	33mA (100ms pulse every 2s)
Isolation voltage ($V_{SO,min}$ - $V_{SO,max}$)	12.5-15V DC
Reconnect voltage ($V_{SC,min}$ - $V_{SC,max}$)	12.8-19.1V DC

Continued on next page

Technical data

Continued

Alarm level analogue value	55	
Status indicator	Alarm	Red
	Fault	Flashing Yellow
	Isolate	Yellow
	Poll	Green
Operating temperature	-40°C to 70°C	
Humidity	0% to 95% RH (no condensation or icing)	
Vibration, impact and shock	EN 54-5	
IP Rating	IP54	
Standards & approvals	SA5000-400	SA5100-400
	EN 54-5, CPR & LPCB	EN 54-5, EN 54-17, CPR & LPCB
Dimensions	100mm diameter x 38.5mm height (50.5mm height with XPERT 8 Intelligent Mounting Base)	
Weight	83g	
Materials	Housing: White polycarbonate UL94-V0	
	Terminals: Tin plated stainless steel	

Heat detector classifications are defined by EN 54-5 as shown in Table 1, each class specifies an application temperature and a static response temperature. Application temperatures define the environmental temperatures the detector can be expected to experience in non-fire conditions. Classes should be selected so that the maximum application temperature is not exceeded. The static response temperature indicates the temperature which the device will produce an alarm signal. In addition to the basic classification a detector may be given an “R” or “S” suffix.

The “R” suffix indicates that the detector has been designed to have a rate-of-rise characteristic. “R” suffix detectors will produce an alarm signal when exposed to a rapid temperature increase. Slower temperature rises will not generate an alarm unless they exceed the static response temperature. A “R” suffix detector will therefore give a rapid fire response even when starting from an ambient temperature well below its typical application temperature.

The “S” suffix indicates that the detector will not produce an alarm signal below its minimum static response temperature even when exposed to high rates of rise of air temperature.

Soteria Heat Detector has eight available modes which correspond to eight “classes” as defined in EN 54-5. To ensure backwards compatibility, modes 1 to 5 inclusive are identical to the modes used in Discovery Heat Detectors. Modes 6, 7 and 8 provide additional heat detector classes and are exclusively available to CoreProtocol enabled fire control panels. Each class corresponds to a different response behaviour and is designed to be suitable for a range of application temperatures and fire risks. The static response temperatures for all modes are given in Table 1.

Electrical Considerations

The Soteria detector is designed to be connected to a two-wire loop circuit carrying both data and power. A version with a short-circuit isolator integrated into the detector head is also available.

Operating Principles

The low profile design of the Soteria Heat Detector is sleek and evolutionary, with a 360° LED indicator which illuminates red when in alarm, yellow to indicate a fault and green to indicate protocol activity.

- Dual heat sensors to ensure an accurate response in all orientations
- Eight operating modes

Application

Fire detectors should always be installed in accordance with all local and national laws and codes of practice.

A “R” suffix detector is suitable for areas such as unheated warehouses in which the ambient temperature may be very low for long periods.

A “S” suffix detector is suitable for areas such as kitchens and boiler rooms, where large rapid temperature changes are considered normal.

Table 1 Soteria Heat Detector response modes

Mode	Class EN 54-5	Application Temperature		Static Response Temperature		
		Typical	Maximum	Minimum	Typical	Maximum
1	A1R	25°C	50°C	54°C	57°C	65°C
2	A2R	25°C	50°C	54°C	60°C	70°C
3	A2S	25°C	50°C	54°C	60°C	70°C
4	CR	55°C	80°C	84°C	90°C	100°C
5	CS	55°C	80°C	84°C	90°C	100°C
6*	BR	40°C	65°C	69°C	74°C	85°C
7*	BS	40°C	65°C	69°C	74°C	85°C
8*	A1S	25°C	50°C	54°C	57°C	65°C

* Note: Modes 6, 7 & 8 are exclusively available to fire control panels running CoreProtocol (if supported).



INVESTORS
IN PEOPLE

A HALMA COMPANY

Device Addressing

A universal XPERT 8 card is supplied with all XPERT 8 Intelligent Mounting Bases. Using a coding guide, pips on the card are removed to set the address of the detector. This simplifies and speeds up installation, commissioning and maintenance. The address location remains the same no matter how often detectors are replaced.

When Soteria devices are used with CoreProtocol, device auto-addressing can be enabled by fire control panels that have been designed to incorporate this feature.

Communication

Soteria uses the new digital CoreProtocol to allow more advanced control and configuration, whilst maintaining backwards compatibility with previous generations of Apollo products – XP95 and Discovery. Discovery and CoreProtocol make use of the Normal, Read and Write modes with additional non-volatile data fields made available to the fire control panel.

Backward Compatibility

Soteria detectors have been designed to operate on XP95 and Discovery loops. This allows for Soteria detectors and bases to operate on existing systems and for Soteria detectors to operate on XP95 and Discovery bases (XPERT 7 Intelligent Mounting Base).

It should be noted that not all features of Soteria will be available when used with XP95 or Discovery fire control panels. If Soteria detectors are used with XP95 fire control panels incorporating drift compensation algorithms, these must be disabled when communicating with Soteria devices.

When Soteria detectors are used with an XPERT 7 Intelligent Mounting Base on a CoreProtocol system, Soteria devices will have a +128 address offset due to only 7 address pips being available on the XPERT 7 card. For example, an XPERT 7 card set at 32 will address as 160 on CoreProtocol with Soteria detectors.

Maintenance & Service

Soteria detectors have been designed with a comprehensive set of features to support maintenance and service, from self test capabilities to drift compensation warnings on dirty detectors.

The new FasTest® mode facility on Soteria can be enabled within a fire control panel that incorporates this feature. This facilitates quicker testing of detectors with appropriate test equipment. FasTest disables the transient rejection algorithms to allow a faster detector response, whilst ensuring the detectors absolute sensitivity remains identical to mode 3. A visual pass/fail indication is provided by the detector and overall, FasTest reduces commissioning and maintenance time.

Maintenance has to be performed in accordance with all applicable standards. Clean the detector externally using a soft damp cloth. For full cleaning and recalibration detectors should be returned to Apollo Fire Detectors.

Figure 1 Soteria Heat Detector with XPERT 8 Intelligent Mounting Base dimensional drawing

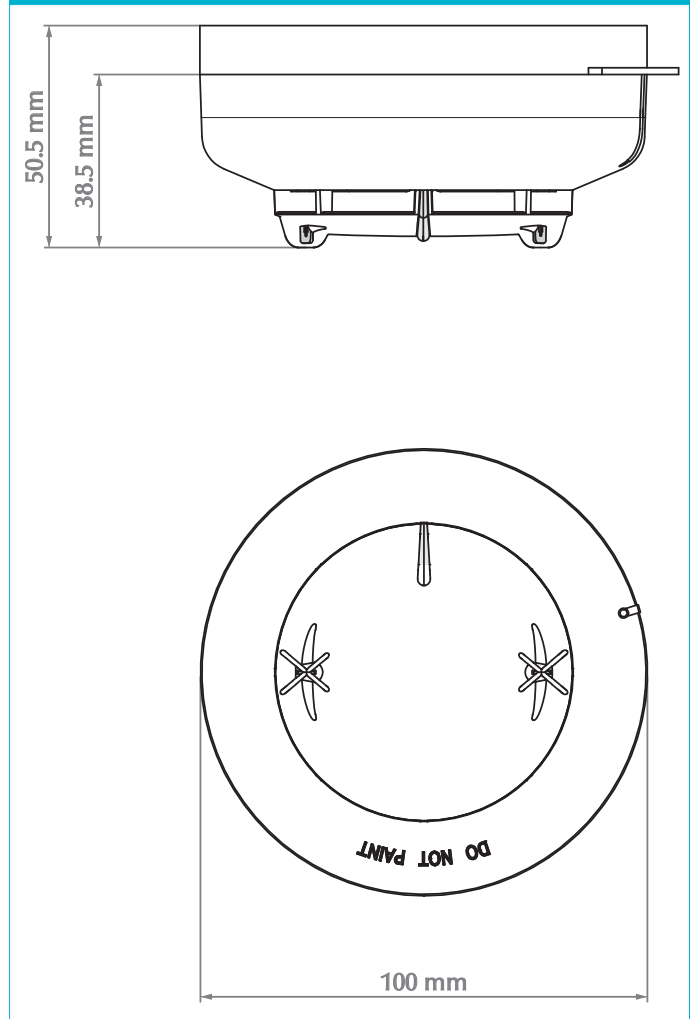

Figure 2 XPERT 8 Intelligent Mounting Base



EMC Directive 2004/108/EC

The Soteria Heat Detector complies with the essential requirements of the EMC Directive 2004/108/EC, provided that it is used as described in this datasheet.

A copy of the Declaration of Conformity is available from Apollo on request.

Conformity of the Soteria Heat Detector with the EMC Directive does not confer compliance with the directive on any apparatus or systems connected to it.

Construction Products Regulation 305/2011

The Soteria Heat Detector complies with the essential requirements of the Construction Products Regulation 305/2011.

A copy of the Declaration of Performance is available from Apollo on request.



**INVESTORS
IN PEOPLE**

A HALMA COMPANY